

#### Key Features :

- Whole Casting Hydraulic pump
- Integrated Valve Core
- Rubber Coated Handle Comfortable
- Powder Coated Chassis Made of High grade steel
- Body Welded by Auto Machine



**Heavy Duty Type**



**Standard Type**



**180x50 Nylon wheel**



**180x50 Polyurethane wheel**



**180x50 Rubber wheel**



**200x50 Polyurethane wheel**

#### DIMENSIONS

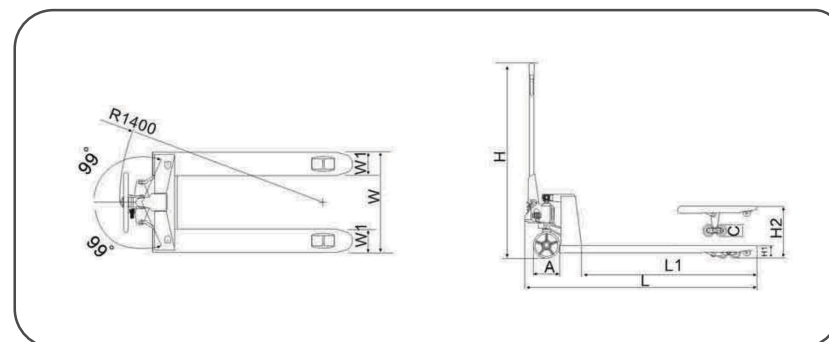

*\*On Demand Custom Specifications are Available\**

#### TECHNICAL SPECIFICATIONS

MODEL	RB-101			
Capacity	Kg	2500	3000	5000
Min.fork height (H1)	mm	75/85	75/85	85
Max.fork height (H2)	mm	185/195	185/195	195
Lifting height	mm	110	110	110
Fork length (L1)	mm	1150/1220	1150/1220	1150/1220
Single fork width (W1)	mm	160	160	160
Width overall forks (W)	mm	550/685	550/685	550/685
Fork wheel-single	mm	74x93/80x93	74x93/80x93	80x93
Fork wheel-tandem (C)	mm	74x70/80x70	74x70/80x70	80x70
Steering wheel (A)	mm	180x50	180x50	180x50/180x52
Self weight	kg	73-92	73-92	102-175
Qty/20 feet container	kg	180/144	180/144	180/144