



**RB INDUSTRIAL
EQUIPMENTS**

RB-104

Hydraulic Fully Electric Pallet Truck RB-104

Key Features:

- Fully Electric
- Compact Design
- Easy Operation
- Battery-Powered
- Versatile
- Low Maintenance
- Improved Efficiency
- Quiet and Eco-Friendly
- Ideal for Warehouses

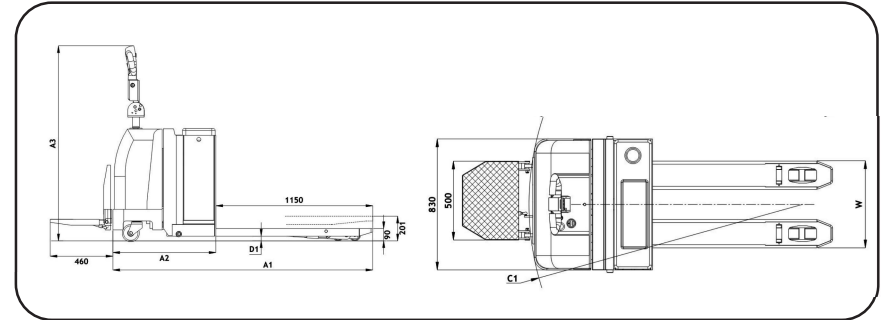

On Demand Custom Specifications are Available

Walkie type also available

TECHNICAL SPECIFICATIONS

MODEL	RB-104			
Drive unit		Electric	Electric	Electric
Load capacity	Kg	2000	2500	3000
Load center	mm	600	600	600
Front wheel dimensions	mm	80x70	80x70	80x70
Rear wheel dimensions	mm	80x36	80x36	80x36
Traction wheel	mm	250x80	250x80	250x80
Lifting height	mm	200	200	200
Handle Height (A3)	mm	1450	1450	1450
Fork clearance from ground (D1)	mm	80	80	80
Fork Dimensions	mm	1220x160x50	1220x160x50	1220x180x50
Total length (A1)	mm	1650	1940	1940
Total width (W)	mm	720	720	720
Maximum forks width	mm	550/685	550/685	550/685
Length (Face to Fork) (A2)	mm	760	830	830
Turning radius (Open pedal) (C1)	mm	1450	1763	1763
Lifting speed (laden/unladen)	m/s	40/30	40/30	40/30
Lowering speed (laden/unladen)	m/s	22/30	22/30	22/30
Truck weight (without battery)	kg	650-670	650-670	650-670
Battery volts/ampere	v/ah	2Vx12/210AH	2Vx12/210AH	2Vx12/210AH
Battery charger	ac	AC220V/50HZ DC24V/40A	AC220V/50HZ DC24V/40A	AC220V/50HZ DC24V/40A