

DIMENSIONS

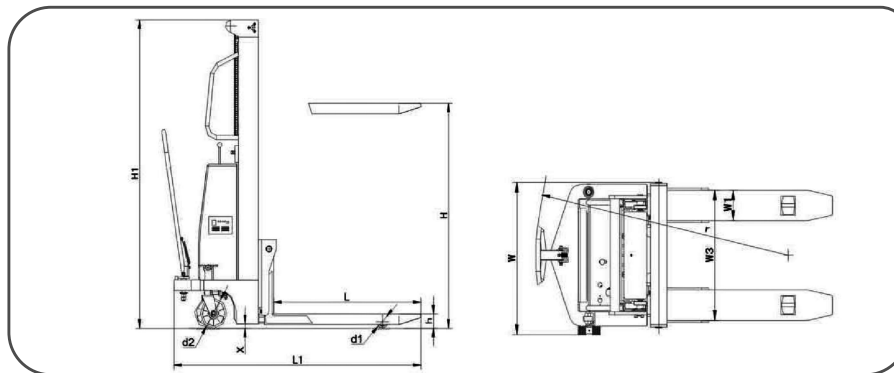

- Handle-castor chain assist steering system greatly reduces the labor intensity.
- Equipped with explosion-proof valve, against of sudden drop of forks and prevent operator from harm.
- Over-discharge protection device greatly prolongs the battery life.
- Overall type adjustable forks, which can be lowered to the same level of the legs.
- Chain connect side wheel and handle, easy for steering.
- Easy operating foot brake.

On Demand Custom Specifications are Available

TECHNICAL SPECIFICATIONS

MODEL NO.		RB-106				
Max Height (H)	Kg	1600	3000	3300	4500(Stradded)	4500 (Standard)
Weight (W)	mm	1T, 1.5T, 2T	1T, 1.5T, 2T	1T, 1.5T	1T, 1.5T	1T, 1.5T
Load Center (C)	mm	500	500	500	500	500
Min Height (h)	mm	85	85	85	85	85
Length of Fork (L)	mm	1000	1000	1000	1000	1000
Width of Fork (W3)	mm	680	680	680	680	680
Ground clearance (x)	mm	25	25	25	25	25
Max Lift Speed (Unload)	mm/s	90+10%	90+10%	90+10%	90+10%	90+10%
Max Lifting Speed (Load)	mm/s	60	60	60	63	63
Max lowering Speed (Load)	mm/s	<280	<281	<282	<283	<283
Minimum Turning Radius (R)	mm	1500	1501	1502	1503	1503
Rear Wheel Size (d1)	mm	80x70 - 80x93	80x70 - 80x94	80x70 - 80x95	80x70 - 80x96	80x70 - 80x96
Front Wheel Size (d2)	mm	180x50	180x51	180x52	180x53	180x53
Overall Length (L1)	mm	1700	1700	1700	1750	1750
Overall Width (W)	mm	800	800	800	1470	800
Overall Height (H1)	mm	1650-2300	1650-2301	1650-2302	2250	2250
Battery Capacity		12V-100Ah / 12V-120Ah	12V-100Ah / 12V-120Ah	12V-100Ah / 12V-120Ah	12V-100Ah / 12V-120Ah	12V-100Ah / 12V-120Ah
Charger		Ac220V/50Hz Dc12V/20A	Ac220V/50Hz Dc12V/20A	Ac220V/50Hz Dc12V/20A	Ac220V/50Hz Dc12V/20A	Ac220V/50Hz Dc12V/20A
Lifting Motor	KW	DC24V-1.6KV	DC24V-1.6KV	DC24V-1.6KV	DC24V-1.6KV	DC24V-1.6KV
Gear Pump	mt/r	CBWn-F2.0	CBWn-F2.1	CBWn-F2.2	CBWn-F2.3	CBWn-F2.3
Self Wright of Battery	Kg	28-35 kg	28-35 kg	28-35 kg	28-35 kg	28-35 kg
Self Weight (Without Battery)	Kg	312-475	312-475	312-475	650	650



Straddled Leg

RB-106



Standard Type