



**RB INDUSTRIAL
EQUIPMENTS**

RB-107

Fully Electric Stacker (Walkie) RB-107

Key Features:

- ENVIRONMENT FRIENDLY
- QUIET OPERATION
- LOWER MAINTENANCE COST
- ENHANCED FUNCTIONING
- INCREASED EFFICIENCY
- REDUCED OPERATING EXPENSES

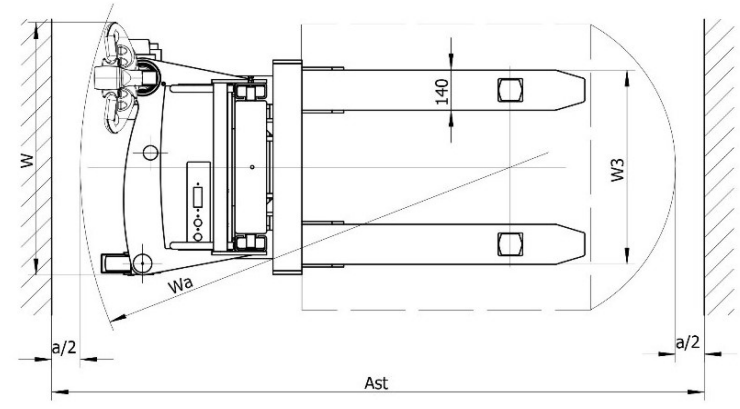
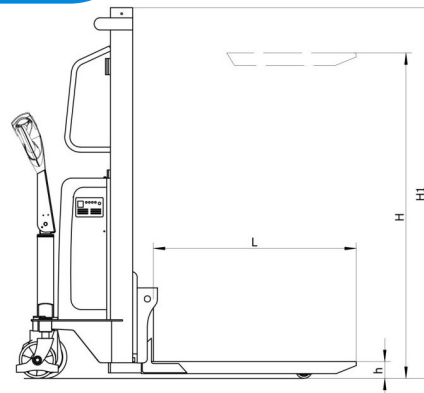

On Demand Custom Specifications are Available



TECHNICAL SPECIFICATIONS

Model	RB-107									
Load Capacity Q	1000 kg					1500 kg				
Lift height H	1600 mm	2000 mm	2500 mm	3000 mm	3500 mm	1600 mm	2000 mm	2500 mm	3000 mm	3500 mm
Total height H1	2080 mm	1580 mm	1830 mm	2080 mm	2330 mm	2080 mm	1580 mm	1830 mm	2080 mm	2330 mm
Load center C	500 mm									
Forks clearance_h	85 mm									
Fork length	1150 mm									
Max. forks width W3	550 mm									
Min. ground clearance x	25 mm									
Traction speed(unlade/lade)	4.5/3 km/h									
Lifting speed (unlade)	90±10% mm/s									
Lifting speed (lade)	60 mm/s									
Lowering speed(lade)	≤300 mm/s									
Min. turning radius r	1500 mm									
Aisle width for pallets	2350 mm									
Front wheel dimensions d1	80x70 mm					80x93 mm				
Rear wheel dimensions d2	180x50 mm									
Total length L1	1800±20 mm									
Total width W	820 mm									
Battery volts/amp	24/80 V/Ah									
Battery charger	AC220V/50Hz DC24V/10A									
Lift motor	DC24V-2.2KW									
Traction motor	DC24V-0.75KW									
Gear pump	CBWn-F2.5 ml/r									
Battery weight	45 kg									
Truck weight (without battery)	300 kg	360 kg	390 kg	420 kg	450 kg	320 kg	380 kg	410 kg	440 kg	470 kg



bajrangsurat@hotmail.com



+91 98241 04354 / +91 76983 54354

www.rbmhe.com

www.trolleyindia.com